

NTC Thermistors, High Temperature Sensors



QUICK REFERENCE DATA

PARAMETER	VALUE	
	2381 633 5....	2381 633 8....
Temperature range	- 40 to + 200 °C	
Resistance value at 25 °C (R ₂₅)	10 to 220 kΩ	
Tolerance on R ₂₅ -value	± 5 % and ± 10 %	
B _{25/85} -value	3977 K	
Tolerance on B _{25/85} -value	± 1.3 %	
Deviation in resistance value due to B-tolerance	see Resistance Values at Intermediate Temperatures table for 2381 633 5.... series	see Resistance Values at Intermediate Temperatures table for 2381 633 8.... series
Ratio R _T /R ₂₅	see Resistance Values at Intermediate Temperatures table for 2381 633 5.... series	see Resistance Values at Intermediate Temperatures table for 2381 633 8.... series
Rated dissipation	100 mW	
Dissipation factor	2.5 mW/K	
Response time	0.9 s	
Thermal time constant τ	6 s	
Temperature coefficient	see Resistance Values at Intermediate Temperatures table for 2381 633 5.... series	see Resistance Values at Intermediate Temperatures table for 2381 633 8.... series
Climatic category	40/155/56	40/200/56
Mass	≈ 0.03 g	≈ 0.14 g

FEATURES

- Small diameter
- Quick response to temperature change
- High stability over a long life
- Wide temperature range from - 40 to + 200 °C
- Resistant to corrosive atmospheres and harsh environments
- Old part number was 2322 633 3/5/8....
- Component in accordance to RoHS 2002/95/EC and WEEE 2002/96/EC

APPLICATIONS

- High temperature measurement control:
 - Domestic appliances
 - Automotive systems
 - Industrial process control

DESCRIPTION

These thermistors have a negative temperature coefficient and are mounted in a glass envelope:

2381 633 5.... (SOD80) without leads and suitable for surface mounting

2381 633 8.... (SOD27) with tinned copper-clad iron leads
 2381 633 3.... is the bandolier version of 2381 633 8.... series

MOUNTING

By soldering

ELECTRICAL DATA AND ORDERING INFORMATION

R ₂₅ (kΩ)	B _{25/85} -VALUE	CATALOG NUMBER 2381 633			
		SOD27 (leadless)		SOD80 (MELF) ¹⁾	
		8.... tinned-copper		5....	
		R ₂₅ ± 10 %	R ₂₅ ± 5 %	R ₂₅ ± 10 %	R ₂₅ ± 5 %
10	3977 K ± 1.3 %	2103	3103	2103	3103
20	3977 K ± 1.3 %	2203	3203	2203	3203
30	3977 K ± 1.3 %	2303	3303	2303	3303
100	3977 K ± 1.3 %	2104	3104	2104	3104
220	3797 K ± 3.0 %	2224	3224	2224	3224

Note

1. Only available in blister tape.

DIMENSIONS in millimeters

Component outline for 2381 633 8.... (SOD27)

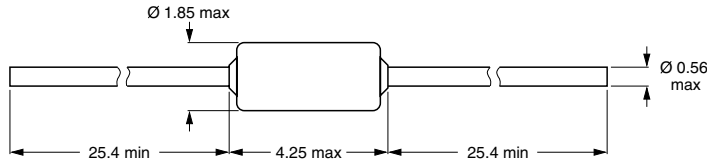

Component outline for 2381 633 5.... (SOD80)

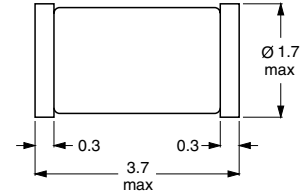

DERATING

Derating curve for 2381 633 5.... series

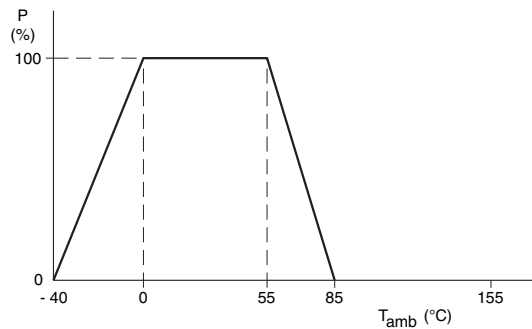

Derating curve for 2381 633 8.... series

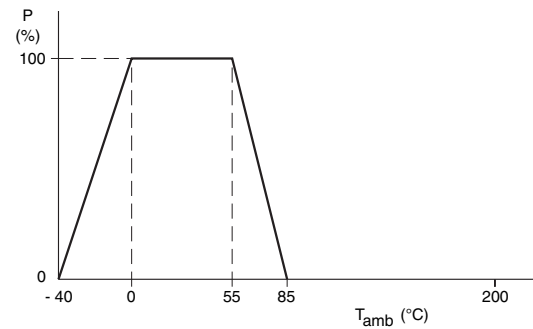

STABILITY AND R-T CHARACTERISTICS

Stability of glass encapsulated NTCs after thermal shock test

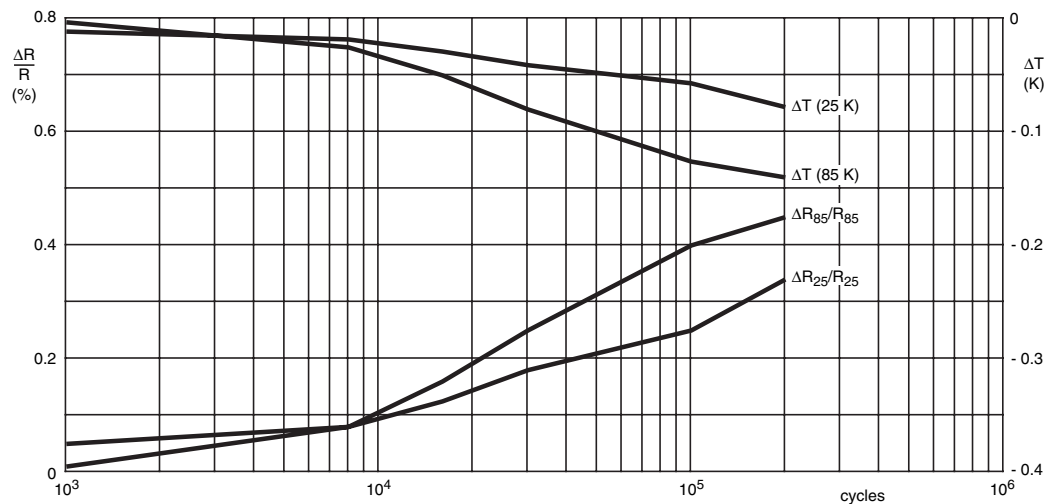



STABILITY AND R-T CHARACTERISTICS

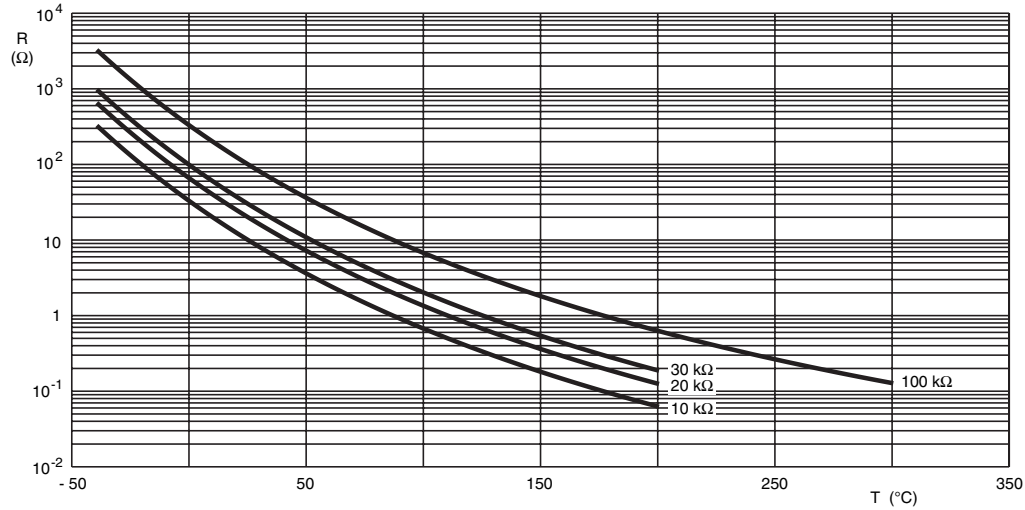

RESISTANCE VALUES AT INTERMEDIATE TEMPERATURES FOR 2381 633 5.... SERIES								
T _{oper} (°C)	R _T /R ₂₅	ΔR DUE TO B-TOLERANCE (%)	TC (%/K)	R ₂₅				
				2381 633 (see note 1)				
				5.103	5.203	5.303	5.104	5.224
-40	33.06	4.65	6.59	330.6	661.2	991.8	3306	-
-35	23.90	4.21	6.37	239.0	478.1	717.1	2390	-
-30	17.47	3.79	6.16	174.7	349.4	524.1	1747	-
-25	12.90	3.38	5.96	129.0	258.0	387.0	1290	-
-20	9.621	2.99	5.77	96.21	192.4	288.6	962.1	-
-15	7.242	2.61	5.59	72.42	144.8	217.3	724.2	-
-10	5.501	2.24	5.41	55.01	110.0	165.0	550.1	-
-5	4.214	1.89	5.24	42.14	84.28	126.4	421.4	-
0	3.255	1.55	5.08	32.55	65.09	97.64	325.5	-
5	2.534	1.22	4.93	25.34	50.67	76.01	253.4	-
10	1.987	0.90	4.78	19.87	39.74	59.62	198.7	-
15	1.570	0.59	4.64	15.70	31.40	47.10	157.0	-
20	1.249	0.29	4.51	12.49	24.98	37.46	124.9	-
25	1.000	0.00	4.38	10.00	20.00	30.00	100.0	220000
30	0.8059	0.28	4.25	8.059	16.12	24.18	80.59	179500
35	0.6534	0.55	4.13	6.534	13.07	19.60	65.34	-
40	0.5329	0.82	4.02	5.329	10.66	15.99	53.29	121300
45	0.4371	1.08	3.91	4.371	8.742	13.11	43.71	-
50	0.3604	1.34	3.80	3.604	7.209	10.81	36.04	83630
55	0.2988	1.58	3.70	2.988	5.976	8.963	29.88	-
60	0.2489	1.82	3.60	2.489	4.978	7.467	24.89	58710
65	0.2084	2.06	3.51	2.084	4.168	6.251	20.84	-
70	0.1753	2.29	3.42	1.753	3.505	5.258	17.53	41920
75	0.1481	2.51	3.33	1.481	2.961	4.442	14.81	-
80	0.1256	2.73	3.24	1.256	2.512	3.769	12.56	30410
85	0.1070	2.95	3.16	1.070	2.141	3.211	10.70	-
90	0.09156	3.16	3.08	0.9156	1.831	2.747	9.156	22390
95	0.07862	3.36	3.01	0.7862	1.572	2.359	7.862	-
100	0.06777	3.56	2.93	0.6777	1.355	2.033	6.777	16720
105	0.05863	3.76	2.86	0.5863	1.173	1.759	5.863	-
110	0.05089	3.95	2.79	0.5089	1.018	1.527	5.089	12630
115	0.04433	4.13	2.73	0.4433	0.8865	1.330	4.433	-
120	0.03873	4.32	2.66	0.3873	0.7747	1.162	3.873	9663
125	0.03395	4.50	2.60	0.3395	0.6791	1.019	3.395	-
130	0.02985	4.67	2.54	0.2985	0.5971	0.8956	2.985	7478
135	0.02633	4.84	2.49	0.2633	0.5265	0.7898	2.633	-
140	0.02328	5.01	2.43	0.2328	0.4656	0.6984	2.328	5851
145	0.02065	5.17	2.38	0.2065	0.4129	0.6194	2.065	-
150	0.01836	5.33	2.32	0.1836	0.3671	0.5507	1.836	4625



RESISTANCE VALUES AT INTERMEDIATE TEMPERATURES FOR 2381 633 8.... SERIES								
T _{oper} (°C)	R _T /R ₂₅	ΔR DUE TO B-TOLERANCE (%)	TC (%/K)	R ₂₅ (kΩ)				
				2381 633 (see note 1)				
				8.103	8.203	8.303	8.104	8.224
-40	33.06	4.65	6.59	330.6	661.2	991.8	3306	-
-35	23.90	4.21	6.37	239.0	478.1	717.1	2390	-
-30	17.47	3.79	6.16	174.7	349.4	524.1	1747	-
-25	12.90	3.38	5.96	129.0	258.0	387.0	1290	-
-20	9.621	2.99	5.77	96.21	192.4	288.6	962.1	-
-15	7.242	2.61	5.59	72.42	144.8	217.3	724.2	-
-10	5.501	2.24	5.41	55.01	110.0	165.0	550.1	-
-5	4.214	1.89	5.24	42.14	84.28	126.4	421.4	-
0	3.255	1.55	5.08	32.55	65.09	97.64	325.5	-
5	2.534	1.22	4.93	25.34	50.67	76.01	253.4	-
10	1.987	0.90	4.78	19.87	39.74	59.62	198.7	-
15	1.570	0.59	4.64	15.70	31.40	47.10	157.0	-
20	1.249	0.29	4.51	12.49	24.98	37.46	124.9	-
25	1.000	0.00	4.38	10.00	20.00	30.00	100.0	220000
30	0.8059	0.28	4.25	8.059	16.12	24.18	80.59	179500
35	0.6534	0.55	4.13	6.534	13.07	19.60	65.34	-
40	0.5329	0.82	4.02	5.329	10.66	15.99	53.29	121300
45	0.4371	1.08	3.91	4.371	8.742	13.11	43.71	-
50	0.3604	1.34	3.80	3.604	7.209	10.81	36.04	83630
55	0.2988	1.58	3.70	2.988	5.976	8.963	29.88	-
60	0.2489	1.82	3.60	2.489	4.978	7.467	24.89	58710
65	0.2084	2.06	3.51	2.084	4.168	6.251	20.84	-
70	0.1753	2.29	3.42	1.753	3.505	5.258	17.53	41920
75	0.1481	2.51	3.33	1.481	2.961	4.442	14.81	-
80	0.1256	2.73	3.24	1.256	2.512	3.769	12.56	30410
85	0.1070	2.95	3.16	1.070	2.141	3.211	10.70	-
90	0.09156	3.16	3.08	0.9156	1.831	2.747	9.156	22390
95	0.07862	3.36	3.01	0.7862	1.572	2.359	7.862	-
100	0.06777	3.56	2.93	0.6777	1.355	2.033	6.777	16720
105	0.05863	3.76	2.86	0.5863	1.173	1.759	5.863	-
110	0.05089	3.95	2.79	0.5089	1.018	1.527	5.089	12630
115	0.04433	4.13	2.73	0.4433	0.8865	1.330	4.433	-
120	0.03873	4.32	2.66	0.3873	0.7747	1.162	3.873	9663
125	0.03395	4.50	2.60	0.3395	0.6791	1.019	3.395	-
130	0.02985	4.67	2.54	0.2985	0.5971	0.8956	2.985	7478
135	0.02633	4.84	2.49	0.2633	0.5265	0.7898	2.633	-
140	0.02328	5.01	2.43	0.2328	0.4656	0.6984	2.328	5851
145	0.02065	5.17	2.38	0.2065	0.4129	0.6194	2.065	-
150	0.01836	5.33	2.32	0.1836	0.3671	0.5507	1.836	4625
155	0.01636	5.49	2.27	0.1636	0.3273	0.4909	1.636	-
160	0.01455	5.65	2.23	0.1455	0.2910	0.4365	1.455	3691
165	0.01303	5.80	2.18	0.1303	0.2606	0.3909	1.303	-
170	0.01169	5.95	2.14	0.1169	0.2339	0.3508	1.169	2973
175	0.01052	6.10	2.09	0.1052	0.2104	0.3156	1.052	-
180	0.00948	6.24	2.05	0.09484	0.1897	0.2845	0.9484	2415
185	0.00857	6.38	2.01	0.08569	0.1714	0.2571	0.8569	-
190	0.00776	6.52	1.97	0.07757	0.1551	0.2327	0.7757	1978
195	0.00704	6.66	1.93	0.07037	0.1407	0.2111	0.7037	-
200	0.00640	6.79	1.89	0.06396	0.1279	0.1919	0.6396	1632

Note

1. Replace dot in last 5-digits of catalog number by a number according to the following list and depending on tolerance on required R₂₅-value:
 - a) 3 for a tolerance of ± 5 %
 - b) 2 for a tolerance of ± 10 %

PACKAGING

BLISTER TAPE AND REEL (2381 633 5....)

Blister tape

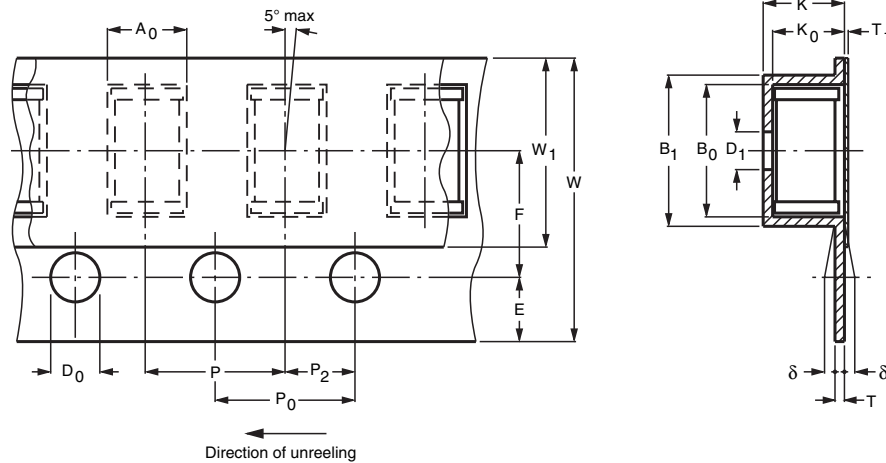

Reel

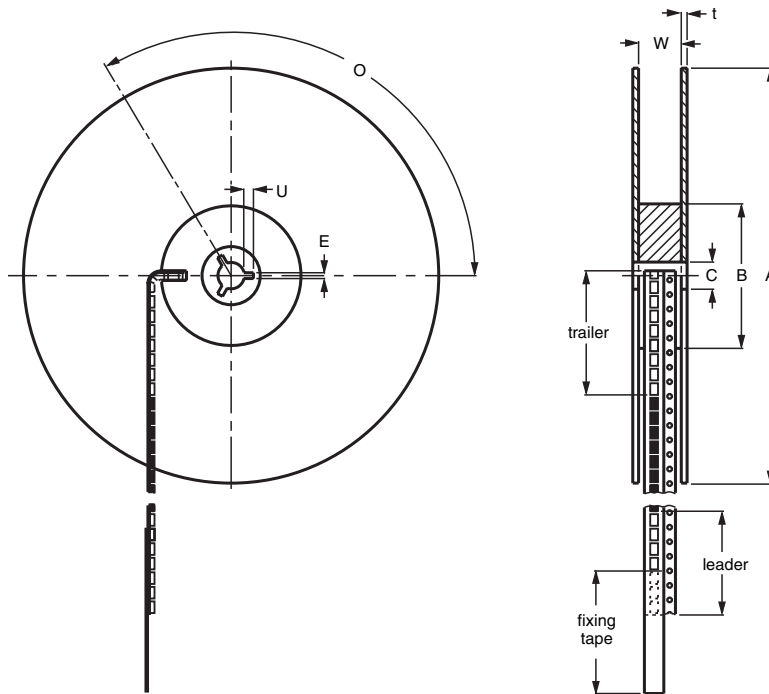

BLISTER TAPE AND REEL DIMENSIONS				
SYMBOL	PARAMETER	NOMINAL DIMENSIONS	TOLERANCE	UNIT
Blister tape				
K	overall thickness	< 2.5	-	mm
POCKET				
A_0	length	2.1	+ 0.3	mm
B_0	width	> 3.8	-	mm
K_0	depth	2.1	+ 0.3	mm

SYMBOL	PARAMETER	NOMINAL DIMENSIONS	TOLERANCE	UNIT
B ₁	outside width	< 4.5	-	mm
P	pitch	4.0	± 0.1	mm
D ₁	hole diameter	1.0	± 0.1	mm
FEED-HOLE				
D ₀	diameter	1.5	± 0.1	mm
P ₀	pitch	4.0	± 0.1	mm
E	distance	1.75	± 0.1	mm
	cumulative pitch error over 10 positions	0	± 0.1	mm
CENTRE LINE				
P ₂	length	2.0	± 0.05	mm
F	width	3.5	± 0.1	mm
FIXING TAPE				
W ₁	width	< 5.5	-	mm
T ₁	thickness	< 0.1	-	mm
CARRIER TAPE				
W	thickness	8.0	± 0.2	mm
δ	bending	< 0.3	-	mm
T	thickness	< 0.4	-	mm
Reel				
FLANGE				
A	diameter	180	+ 0	mm
t	thickness	1.5	+ 0.5	mm
W	space between flanges	9.5	± 0.5	mm
HUB				
B	diameter	62.0	± 1.5	mm
C	spindle hole	12.75	+ 0.15/- 0	mm
KEY SLIT				
E	width	2.0	± 0.5	mm
U	depth	4.0	± 0.5	mm
O	location	120	-	°

THERMISTORS ON BANDOLIER (2381 633 3....)

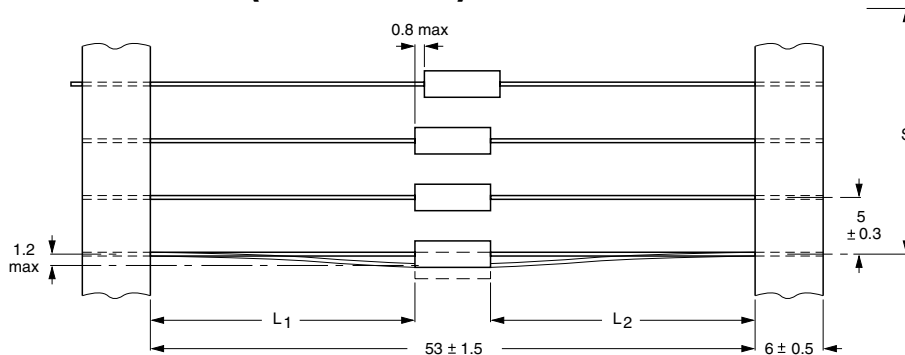

The components are centred so that $|L_1 - L_2| = 1.2 \text{ mm max.}$

The cumulative space (S) measured over 10 spacings = $50 \pm 2 \text{ mm.}$

Note

The bandolier of a 180 mm reel contains at least 2500 devices with no more than 0.5 % empty positions.

Three consecutive empty places may be found provided this gap is followed by 6 consecutive devices.

The carrier tape starts (leader) and ends (trailer) with at least 75 empty positions (equivalent to 300 mm); the covering foil is at least 300 mm. In order to fix the carrier tape a self-adhesive tape of 20 to 50 mm width is applied.



Notice

Specifications of the products displayed herein are subject to change without notice. Vishay Intertechnology, Inc., or anyone on its behalf, assumes no responsibility or liability for any errors or inaccuracies.

Information contained herein is intended to provide a product description only. No license, express or implied, by estoppel or otherwise, to any intellectual property rights is granted by this document. Except as provided in Vishay's terms and conditions of sale for such products, Vishay assumes no liability whatsoever, and disclaims any express or implied warranty, relating to sale and/or use of Vishay products including liability or warranties relating to fitness for a particular purpose, merchantability, or infringement of any patent, copyright, or other intellectual property right.

The products shown herein are not designed for use in medical, life-saving, or life-sustaining applications. Customers using or selling these products for use in such applications do so at their own risk and agree to fully indemnify Vishay for any damages resulting from such improper use or sale.